

Diesel Combined Cycle

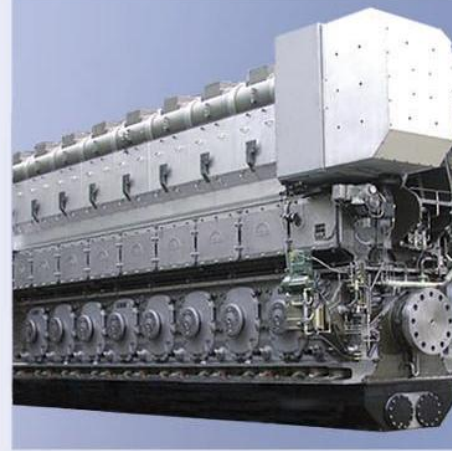

DCC – Reference Design

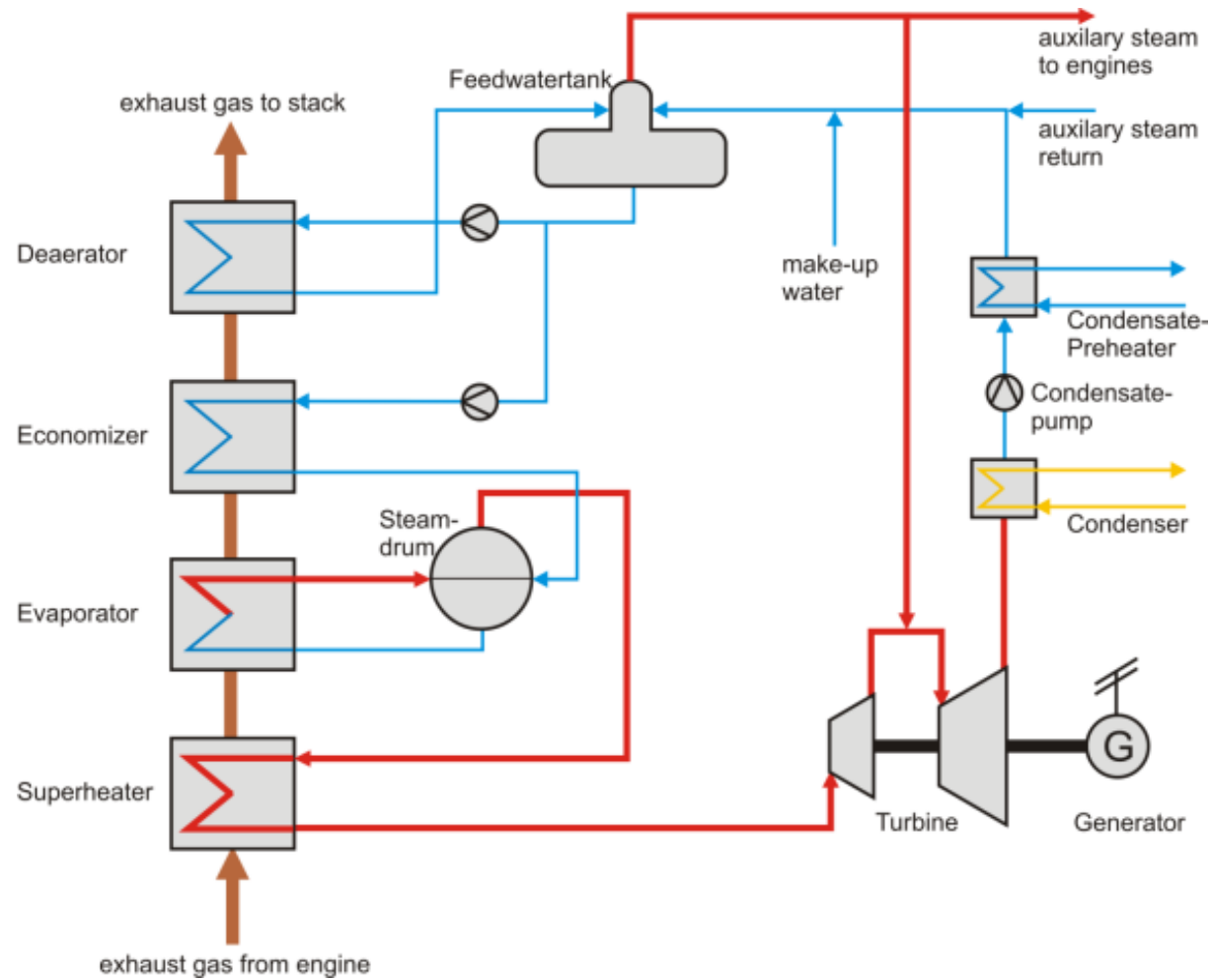

DCC – Reference Design



Main features:

Simple but high efficient!!

- High efficient steam turbine with two pressure levels
- Simple design of HRSG:
 - only one high pressure stage
 - simple low cost second stage
- Condensate preheating with engine cooling water
- Water or air cooled condenser

Increase of efficiency with DCC

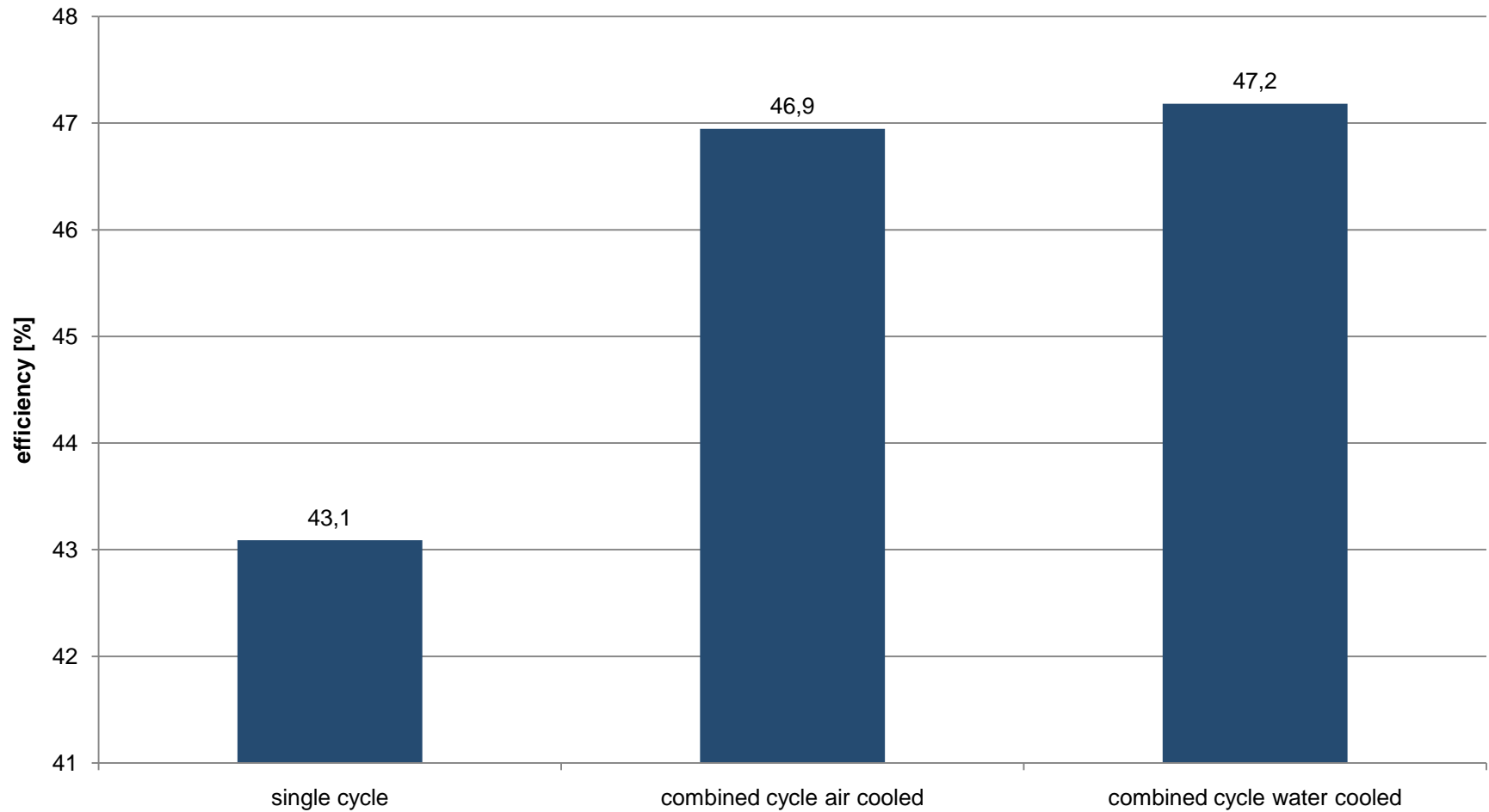

Additional area needed



Example: 6 x 18V 48/60

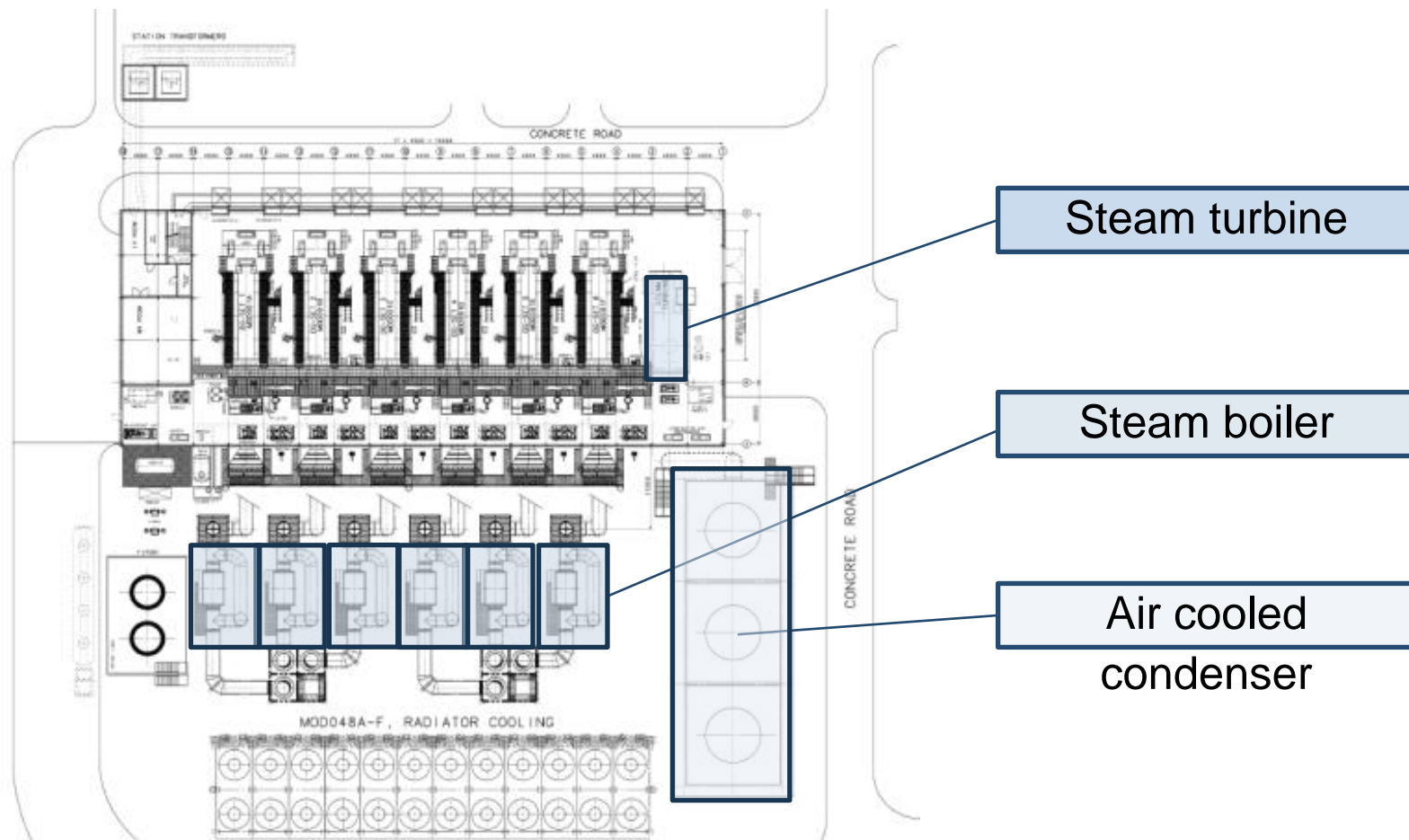

Steam turbine

Steam boiler

Air cooled
condenser

Pictures of combined cycle plant





