

# Control Valves

## Retrofit for steam turbines

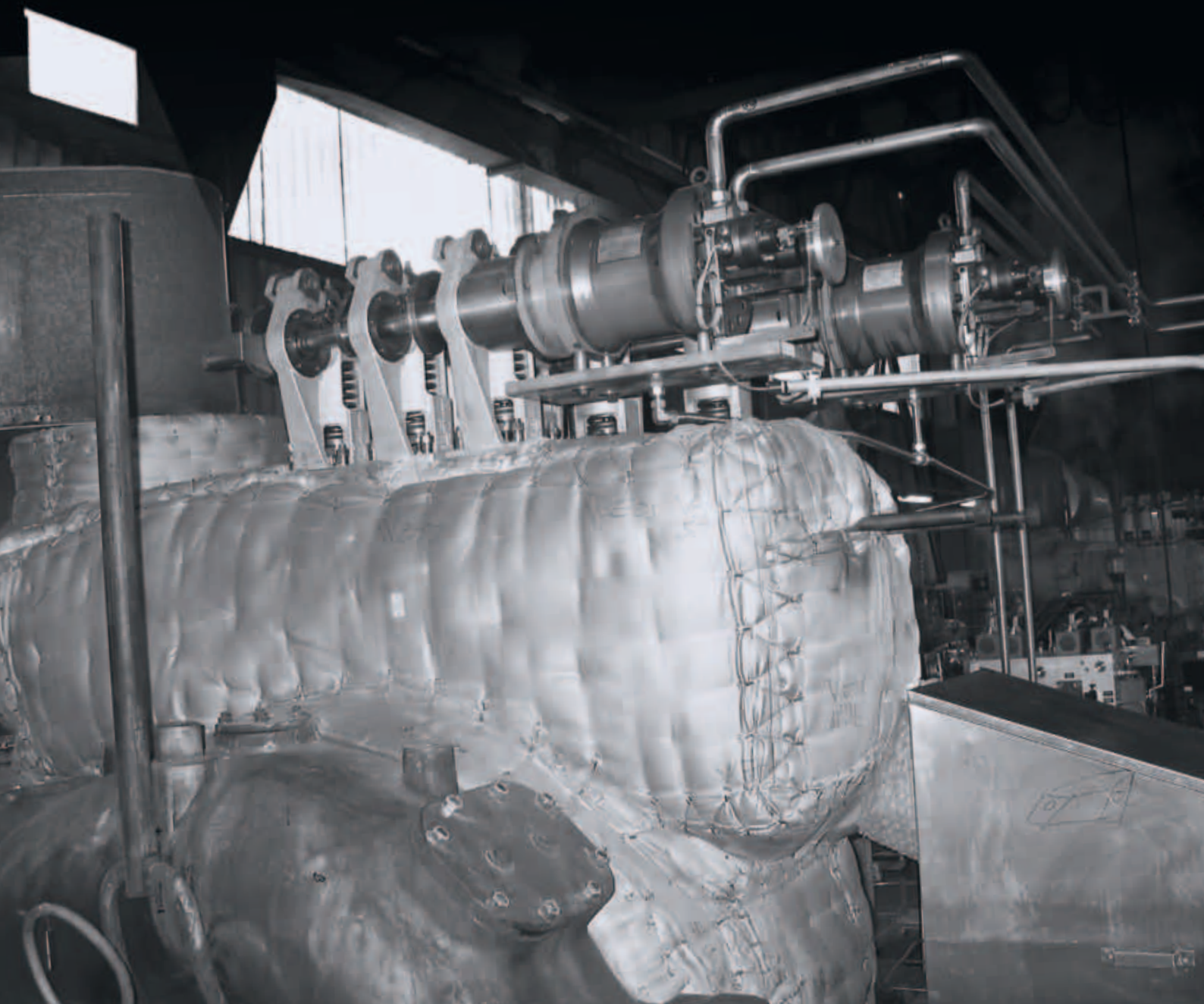

# Control Valves

## Improved reliability for steam turbines

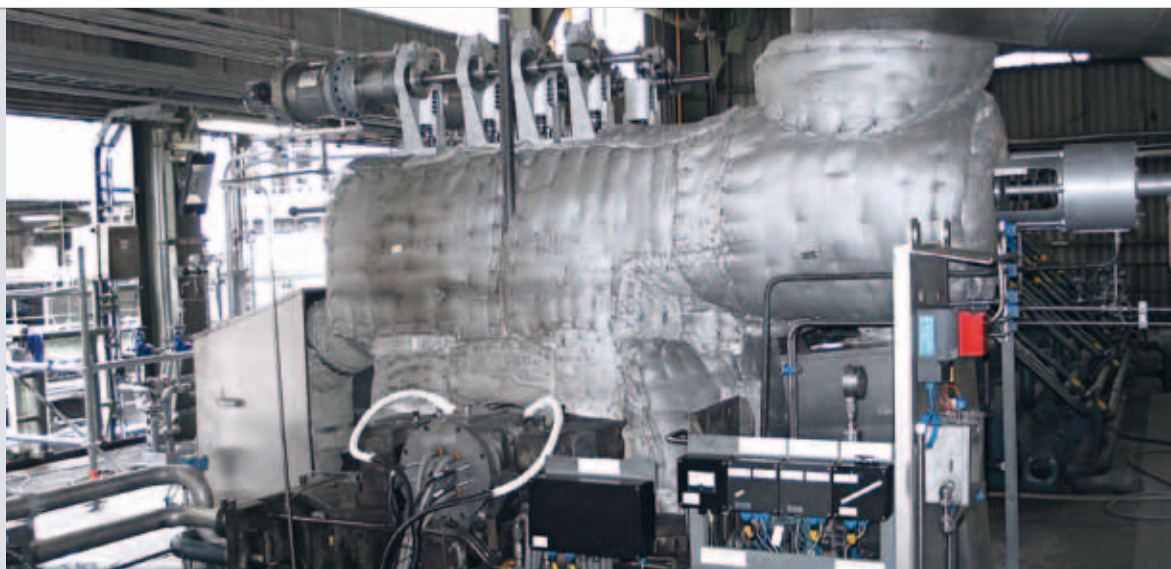

*Steam turbine type DEK 710 equipped with improved steam control valves and actuators*

MAN PrimeServ has enhanced the steam control valves of type DG/DK/DEG/DEK steam turbines to significantly increase availability and reliability. All actuators have been moved to the “cold end” of the live-steam supply casing to ensure maximum reliability. Additionally, all components have been mechanically reinforced. The new control and protection system of MAN PrimeServ offers customers who want to meet the new safety requirements of API 670 the perfect control valve system for their steam turbine.

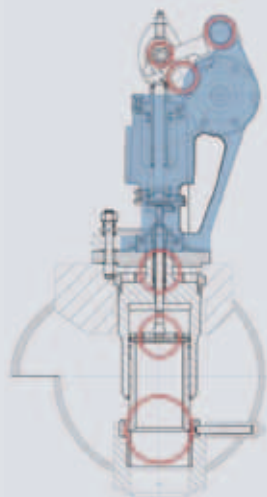

*New steam control valve design including actuator (improved components highlighted/marked)*

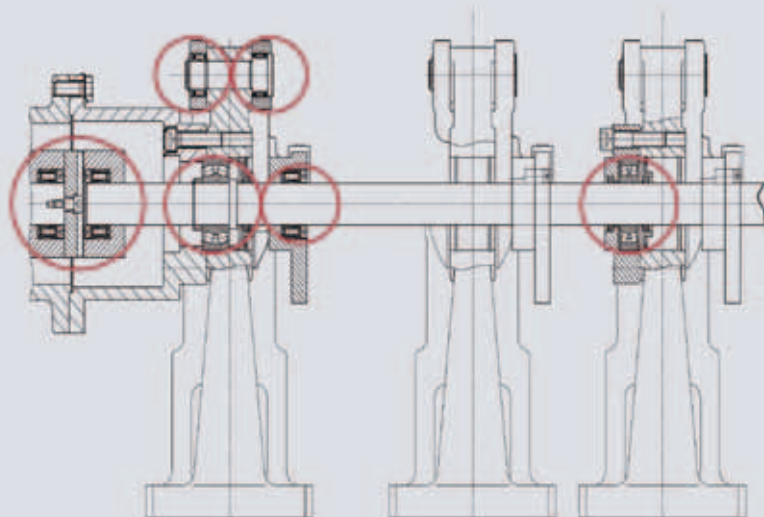

*Improved steam control valve actuators*

## Challenge

The steam turbine control valve system with its actuators has to operate at high temperatures at the live-steam inlet. Actuators experience high wear, especially when the steam turbine is situated outdoors. After a period of operation, components may fail and cause an unplanned outage. MAN PrimeServ provides a significantly improved and strengthened control valve for increased reliability and availability.

## Solution

The design of the control valves and their actuator system was completely reviewed. The actuator design, valve spring system and hinges have been strengthened and improved.

Proven design features such as mechanical linearization of the control valve characteristics, unsurpassed maintainability, well-proven self-sealing and a sealing system for valve spindles have been retained. The units are designed to replace the previous control valves and actuators.

The new components are coordinated perfectly to the new electro-hydraulic speed control systems with fully integrated electronic overspeed protection for steam turbine types DG/DK/DEG/DEK. The new valve drive is therefore recommended for all customers with installations that include such machines.

## Advantages

- reinforced body
- strengthened lever
- improved spring material with increased spring forces
- roller bearings for camshaft and at all hinges
- improved adjustment of closed position
- improved direct drive of spindle
- direct alignment of camshaft drive and camshaft (trestle for drive is no longer necessary)
- bearings and actuator are situated at the “cold end”
- cam alignment is simplified

All data provided in this document is non-binding. This data serves informational purposes only and is especially not guaranteed in any way. Depending on the subsequent specific individual projects, the relevant data may be subject to changes and will be assessed and determined individually for each project. This will depend on the particular characteristics of each individual project, especially specific site and operational conditions. Copyright © MAN Diesel & Turbo - D02091103ZEN Printed in Germany G.M.C.-OH106100.5

**MAN Diesel & Turbo**

13507 Berlin, Germany

Phone +49 30 440402 0

Fax +49 30 440402 2000

mtprimeserv@man.eu

[www.mandieselturbo.com](http://www.mandieselturbo.com)

24/7 Hotline: +49 208 692 9000