

MAN Diesel

PrimeServ Holeby

GenSets

Østervej 2

4960 Holeby, Danmark

Phone +45 54 69 31 00

Fax +45 54 69 30 31

PrimeServ-hol@mandiesel.com

www.mandiesel.com

L16/24 GenSets 2008 Update

PrimeServ Retrofitting

L16/24 GenSets

2008 update package

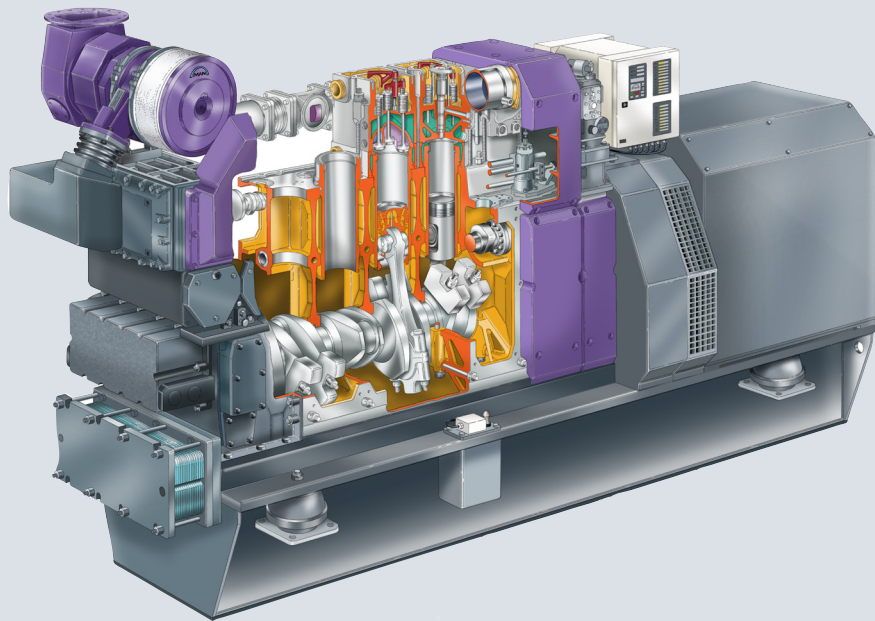

The L16/24 engine type was successfully introduced to the market in 1995. The success of the L16/24 has been proved by the market as our present backlog of GenSets on order or in operation counts more than 2,000.

As indicated with the graphic to the right, it is a part of our strategy to constantly evaluate the market feedback and the service experience for all our products.

On the basis of information gathered over the years, we introduced an updated / upgraded version of the L16/24 in 2008. Basically, this update included the following details:

- Cylinder output increased from 100 kW/cyl to 110 kW/cyl
- Standard application of a low load charge air pre-heating system
- Improved valve train with low lift cams

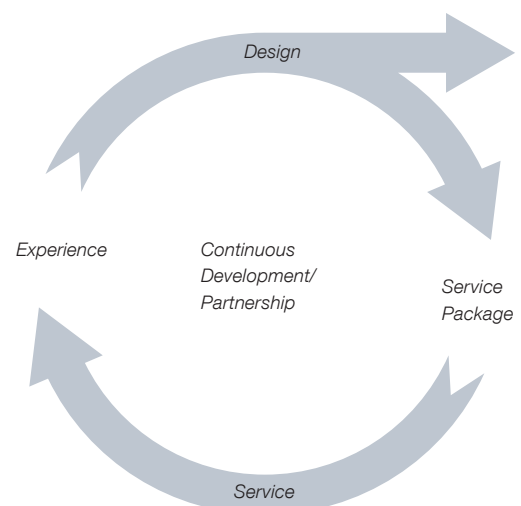

By application of an improved turbocharger and improved valve timing, the engine output was upgraded to 110 kW/cyl.

Our experience with the Heavy Fuel Oil (HFO) on the market has shown a tendency of decreasing ignition properties, which in general, may lead to operational problems, especially in the low load area. In order to improve the ability of low load operation, it was decided to apply a charge air preheating system as a standard application for the 2008 version.

By further development of the valve train and cam system, it has been possible to reduce the risk of engine damage if a valve is sticking in the cylinder head - as no mechanical contact is possible at the updated design. For details, see below figure.

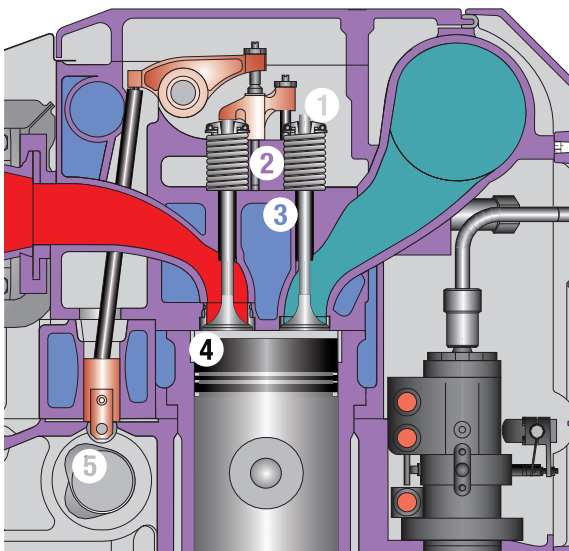

1. New rotacaps 2. New valve springs 3. New valve guides,
4. Valve pockets in piston 5. Reduced cam/valve lift

For our customers to gain the benefit of the introduced updates of the 2008 L16/24 version, we are pleased to announce that PrimeServ Holeby, based on the 2008 design updates, has developed the update packages as listed below for retrofit on existing GenSets in the market.

The following update packages are available for the L16/24 GenSets:

- Retrofit of turbochargers to NR12S/ NR14S
- Retrofit of charge air preheating systems
- Retrofit of the updated valve train and cams

The above updates can be picked and applied as single items or as a whole that will update your GenSets to the 2008 version.

If you find the above of interest, we will be pleased to review your actual GenSet application and, on the basis of this, prepare an offer for introduction of a tailor-made update package for your fleet.

Newbuilding in your fleet

If you have new orders for vessels with the L16/24 GenSet, we recommend to contact the yard/engine builder in order to verify the actual design of the GenSets specified for your newbuildings.

For further details, contact PrimeServ Holeby.